



राष्ट्रीय प्रौद्योगिकी संस्थान मेघालय
NATIONAL INSTITUTE OF TECHNOLOGY MEGHALAYA
(An Institute of National Importance under Ministry of Education, Govt. of India)
Bijni Complex, Laitumkhrah, Shillong-793003
Ph. 0364-2501215, FAX 0364-2501113

Ref. No. NITMGH/PS/FUR-LH/PC/2024-25/ 1630

Date: 24.10.2024

NOTICE INVITING TENDER

Online bids are invited from National Institute of Technology Meghalaya, Shillong for “SUPPLY AND INSTALLATION OF 2/3-SEATER INTEGRATED DUAL DESK-BENCH FURNITURE IN THE LECTURE HALL AT NIT MEGHALAYA, PERMANENT CAMPUS, SAITSOHPEN, SOHRA, 793108, MEGHALAYA” as mentioned in the BOQ. Rates shall be quoted in the Microsoft Excel sheet uploaded as BOQ on the CPPP site <https://eprocure.gov.in/eprocure/app>. Only online bids will be accepted. Offline /Manual bids shall not be accepted.



Prescribed Tender document, detailed fees and specifications, bid instructions and Terms & Conditions can be downloaded from the CPP Portal (<https://eprocure.gov.in/eprocure/app>) or from the Institute website (<http://www.nitm.ac.in/>).

CRITICAL DATES:

| | |
|----------------------------|-------------------------|
| Date of Publishing | 25.10.2024 at 12:00 hrs |
| Bid Document Download Date | 25.10.2024 at 12:00 hrs |
| Bid Submission Start Date | 25.10.2024 at 12:00 hrs |
| Bid Submission End Date | 14.11.2024 at 13.00 hrs |
| Bid Opening Date | 14.11.2024 at 14:00 hrs |

Bids shall be submitted online only at CPPP website: <https://eprocure.gov.in/eprocure/app>.

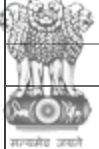
Registrar
कुलसचिव
REGISTRAR
राष्ट्रीय प्रौद्योगिकी संस्थान मेघालय
National Institute of Technology Meghalaya

| Government eProcurement System | | eProcurement System Government of India | | | | |
|---|---|---|---|------------------------------|--|--------------------|
| | | Tender Details | | | | |
|  | | Date : 24-Oct-2024 05:43 PM | | | | |
| | |  Print | | | | |
| Basic Details | | | | | | |
| Organisation Chain | National Institute of Technology Meghalaya Purchase Section - NIT Meghalaya | | | | | |
| Tender Reference Number | NITMGH/PS/FURLH/PC/24-25/1630 | | | | | |
| Tender ID | 2024_NITM_832376_1 | Withdrawal Allowed | Yes | | | |
| Tender Type | Open Tender | Form of contract | Supply | | | |
| Tender Category | Goods | No. of Covers | 2 | | | |
| General Technical Evaluation Allowed | No | ItemWise Technical Evaluation Allowed | No | | | |
| Payment Mode | Offline | Is Multi Currency Allowed For BOQ | No | | | |
| Is Multi Currency Allowed For Fee | No | Allow Two Stage Bidding | No | | | |
| Payment Instruments | | | Cover Details, No. Of Covers - 2 | | | |
| Offline | S.No | Instrument Type | Cover No | Cover | Document Type | Description |
| | 1 | Demand Draft | 1 | Fee/PreQual/Technical | .pdf | Technical Bid |
| | | | 2 | Finance | .xls | Financial Bid |
| Tender Fee Details, [Total Fee in ₹ * - 0.00] | | | EMD Fee Details | | | |
| Tender Fee in ₹ | 0.00 | EMD Amount in ₹ | 6,55,000 | EMD Exemption Allowed | Yes | |
| Fee Payable To | Nil | Fee Payable At | Nil | EMD Fee Type | fixed | |
| Tender Fee Exemption Allowed | No | | | EMD Payable To | National Institute of Technology Meghalaya | |
| | | | | EMD Percentage | NA | |
| | | | | EMD Payable At | Shillong | |
| Click to view modification history | | | | | | |
| Work /Item(s) | | | | | | |
| Title | SUPPLY AND INSTALLATION OF 2/3-SEATER INTEGRATED DUAL DESK-BENCH FURNITURE IN THE LECTURE HALL AT NIT MEGHALAYA, PERMANENT CAMPUS, SAITSOHPEN, SOHRA, 793108, MEGHALAYA | | | | | |
| Work Description | As per Tender Documents | | | | | |
| Pre Qualification Details | Please refer Tender Documents | | | | | |
| Independent External Monitor/Remarks | NA | | | | | |
| Show Tender Value in Public Domain | No | | | | | |
| Tender Value in ₹ | 2,61,96,000 | Product Category | Furniture/ Fixture | Sub category | NA | |
| Contract Type | Tender | Bid Validity(Days) | 120 | Period Of Work(Days) | 60 | |
| Location | NIT MEGHALAYA SAITSOHPEN SOHRA | Pincode | 793108 | Pre Bid Meeting Place | NA | |
| | NA | Pre Bid Meeting Date | NA | Bid Opening Place | Shillong | |

| | | | | |
|--------------------------------|----|----------------------------------|----|--|
| Pre Bid Meeting Address | | | | |
| Should Allow NDA Tender | No | Allow Preferential Bidder | No | |

Critical Dates

| | | | |
|--|----------------------|--|----------------------|
| Publish Date | 25-Oct-2024 12:00 PM | Bid Opening Date | 15-Nov-2024 02:00 PM |
| Document Download / Sale Start Date | 25-Oct-2024 12:00 PM | Document Download / Sale End Date | 14-Nov-2024 01:00 PM |
| Clarification Start Date | NA | Clarification End Date | NA |
| Bid Submission Start Date | 25-Oct-2024 12:00 PM | Bid Submission End Date | 14-Nov-2024 01:00 PM |

Tender Documents

| NIT Document | S.No | Document Name | Description | Document Size (in KB) |
|---------------------|-------------|----------------------|------------------------|------------------------------|
| | 1 | Tendernotice_1.pdf | Notice Inviting Tender | 86.95 |

| Work Item Documents | S.No | Document Type | Document Name | Description | Document Size (in KB) |
|----------------------------|-------------|----------------------|--------------------------|------------------------|------------------------------|
| | 1 | Tender Documents | NIQLECTUREHALL251024.pdf | As per Tender Document | 2184.37 |
| | 2 | BOQ | BOQ_874678.xls | As per Tender Document | 258.00 |
| | 3 | Additional Documents | NIT.pdf | NIT | 70.63 |

Bid Openers List

| S.No | Bid Opener Login Id | Bid Opener Name | Certificate Name |
|-------------|------------------------------|-------------------------|-------------------------|
| 1. | ar.estt@nitm.ac.in | Bantehsonglang Blahwar | Bantehsonglang Blahwar |
| 2. | gitish.dutta@nitm.ac.in | Gitish Kishor Dutta | Gitish Kishor Dutta |
| 3. | shampapurkayastha@nitm.ac.in | Shampa Purkayastha | Shampa Purkayastha |
| 4. | khlain.off.use@nitm.ac.in | KHLAINBORLANG NONGKHLAW | KHLAINBORLANG NONGKHLAW |

GeMARPTS Details

| | |
|---|---|
| Reason for non availability of GeMARPTS ID | Urgent nature of Procurement |
| Remarks | Item not available in GeM |
| Document Name | report_GEM_GARPTS_09102024_LIM8RBK7YG04.pdf |
| Document Size (in KB) | 37.60 |

Tender Properties

| | | | |
|--|--------|---|-----------------------|
| Auto Tendering Process allowed | No | Show Technical bid status | Yes |
| Show Finance bid status | Yes | Stage to disclose Bid Details in Public Domain | Technical Bid Opening |
| BoQ Comparative Chart model | Normal | BoQ Comparative chart decimal places | 2 |
| BoQ Comparative Chart Rank Type | L | Form Based BoQ | No |

TIA Undertaking

| S.No | Undertaking to Order | Tender complying with Order | Reason for non compliance of Order |
|-------------|------------------------------------|------------------------------------|---|
| 1 | PPP-MII Order 2017 | Agree | |
| 2 | MSEs Order 2012 | Agree | |

Tender Inviting Authority

| | |
|----------------|---|
| Name | Registrar |
| Address | NIT MEGHALAYA Bijni Complex Laitumkhrah shillong 793003 |

Tender Creator Details

| | |
|---------------------|-------------------------|
| Created By | KHLAINBORLANG NONGKHLAW |
| Designation | JUNIOR ASSISTANT |
| Created Date | 24-Oct-2024 05:11 PM |



राष्ट्रीय प्रौद्योगिकी संस्थान मेघालय
NATIONAL INSTITUTE OF TECHNOLOGY MEGHALAYA
Saitsophen, Sohra -793108, Meghalaya

Phone: 0364-2501215
Fax :0364-2501113
Web:<http://www.nitm.ac.in/>

Ref. No. NITMGH/PS/FUR-LH/PC/2024-25/1630

Date:24.10.2024.

E-NOTICE INVITING QUOTATION (E-NIQ) FOR SUPPLY AND INSTALLATION OF 2/3-SEATER INTEGRATED DUAL DESK-BENCH FURNITURE IN THE LECTURE HALL AT NIT MEGHALAYA, PERMANENT CAMPUS, SAITSOHPEN, SOHRA, 793108, MEGHALAYA

NIT Meghalaya invites online Tenders through **CPP portal** from eligible Bidders for procurement of Furniture at NIT Meghalaya, Sohra Campus as per details mentioned in the **Annexure-I**, attached herewith.

Prescribed Tender documents, detailed fees, and specifications, bid instructions and Terms & Conditions can be downloaded from the CPP Portal or from the Institute website (<http://www.nitm.ac.in/>). The bidding process (submission and finalization) will be done in online mode through CPP Portal. The bidders may submit/upload their bid through CPP Portal.

“Kindly read the NIQ document carefully before participating. It shall be deemed that submission of bid by the bidder has been done after their careful study and examination of the NIQ terms with full understanding to its implications. Any lack of information shall not in any way relieve the bidder of its responsibility to fulfil its obligations at any stage under the Bid.”

The Director NITM will reject a proposal for award if it determines that the bidder recommended for award has engaged in corrupt or fraudulent practices in competing for, or in executing, the Purchase Order. Fraudulent Practice means a misrepresentation of facts to influence a procurement process and includes collusive practice among bidders (prior to or after Bid submission) designed to establish Bid prices at artificial non-competitive levels and to deprive NITM of the benefits of free and fair competition. Corrupt Practice means offering, giving, receiving, or soliciting of anything of value, pressurizing to influence the action of a public official in the process of this purchase execution.

It is to note that, the item wise quantity as mentioned in Annexure-I may subject to changes as well as some components of the items mentioned in Annexure-I may be excluded during the time of P.O. at the discretion of NIT Meghalaya.

BID INSTRUCTIONS:

01. The offer must be submitted Single Packet in CPP Portal consisting of both technical and financial bids.
02. **Submission of Compliance Certificate:** Duly filled in and signed Compliance Certificates (as per format at *Annexure-II A&B*) are a must with the technical bid.
03. **Bid not transferable:** The bid documents are not transferable and the seal and signature of the authorized official of the firms must appear on all the papers and envelopes submitted.
04. The quantity mentioned for each item in *Annexure-I* may increase/decrease depending on requirements.
05. The GST Registration Certificate should be closed along with the tender documents.
06. The relevant catalogue of the items (if any) must be closed.
07. **Interested vendors may interact with Dr. M. Longshithung Patton, Chairman Furniture Committee, NIT Meghalaya, for any queries @ email ID @ mlpatton@nitm.ac.in**
08. For e-way bills the successful vendor must apply online via <https://ewaybill.nic.in/ewb.html>.

NIO TERMS & CONDITIONS:

01. **Rates:** Rates quoted in the Price Bid should be on DOOR DELIVERY at NIT MEGHALAYA, NIT MEGHALAYA, PERMANENT CAMPUS, SAITSOHPEN, SOHRA – 793108, MEGHALAYA basis as per details below to be quoted in the BOQ: -

| Group: | Item Sl. No. | Item name | |
|---------|--|-----------|------|
| Sl. No. | Particulars | | Rate |
| I | Basic Price (per unit) | | |
| | Discount if any | | |
| | Total | | |
| | GST (pl. breakup CGST/SGST/IGST) | | |
| | Total (per unit) | | |
| | Grand total for the item | | |
| II | Transportation charges up to NIT MEGHALAYA, PERMANENT CAMPUS, SAITSOHPEN, SOHRA-793108, MEGHALAYA | | |
| III | Transit Insurance covering all risk up to 10 days after delivery (if applicable) | | |
| | Grand total on door delivery at NIT MEGHALAYA, PERMANENT CAMPUS, SAITSOHPEN, SOHRA-793108, MEGHALAYA | | |

Note: Vague terms like “packing, forwarding, transportation etc. extra” without mentioning the specific amount will not be accepted. Such offers shall be treated as incomplete and rejected.

02. **Quotations must be submitted in Indian Rupees (INR) only.** If goods are to be imported, the quotations shall include all charges for customs clearance, clearing agent fees, landing port handling charges, insurance etc. and onward transportation of the goods from the port/airport of landing for door delivery up to NIT MEGHALAYA, PERMANENT CAMPUS, SAITSOHPEN, SOHRA - 793108, MEGHALAYA.
03. NIT Meghalaya has a valid registration with the Department of Scientific and Industrial Research (DSIR), Ministry of Science & Technology, Government of India for availing Customs/Central Excise Duty exemption. NIT Meghalaya will provide all necessary certificates, authorizations and documents required for clearing the consignment and for onward transportation NIT MEGHALAYA, PERMANENT CAMPUS, SAITSOHPEN, SOHRA - 793108, MEGHALAYA.
04. All documents submitted should be digitally signed by the bidder.
05. (a) Either the Indian agent on behalf of the Principal / OEM or Principal / OEM itself can bid but both (Indian agent and Principal/OEM) cannot bid simultaneously for the same item/ product in the same tender.
(b) If an agent submits bid on behalf of a particular Principal / OEM, the same agent shall not submit a bid on behalf of another Principal / OEM in the same tender for the same item / product.
06. Bidder must unconditionally accept all terms and conditions stipulated in the tender document and all pages of the bid including all enclosures should be numbered and must be duly filled in and digitally signed by the bidder or his authorized representative.
07. The bidder must also upload a digitally signed copy of the **Tender Acceptance Letter** in the format given in Annexure-V.
08. **Validity of Quotation: Quoted rates must be valid for 120 days from the date of quotation.**
09. **Warranty: The quoted items must be warranted for a minimum of three (03) years from the date of successful installation.**
10. **Literature must:** All the quotations must be supported by the printed technical data sheet/ literature and the specifications mentioned in the quotation must be reflected/ supported by such printed technical

datasheet/ literature. The make, model no. and specifications quoted should invariably be highlighted in the datasheets/literature for easy reference.

11. Details of the supply of similar items to Institutes of National Importance such as NIT`s/IIT`s/ CFTI`s is a must and should be provided along with the proof of satisfactory completion report. However, the final decision of acceptance rests with the competent authority.
12. **Presentation:** Bidders may be called upon to give a full presentation of the quoted items at the NIT Meghalaya campus as a support of their Technical Specifications and for any clarifications.
13. **After-Sales Service:** A vendor should provide post-sales service provider for repair, maintenance, AMC etc. in Northeast /Eastern parts of India. Bidders should clearly state the detailed address, contact number, and email ids of the ‘after-sales service provider’, in Bidder’s Details under Statutory Cover without which their offers shall be liable for rejection. Service against any complaint must be provided within 24 hours.
14. **EMD:** - Earnest Money: Refundable earnest money deposit (EMD) of **Rs. 6,55,000/- (Rupees Six Lakh Fifty Thousand only)** only through demand draft drawn (of any Nationalized/Scheduled Bank) in favour of “**National Institute of Technology Meghalaya**”, payable at Shillong, will have to accompany the technical Bid. The EMD of unsuccessful bidders shall be returned without any interest after award of contract. EMD of the successful bidder will be released without interest on submission of the Performance Bank Guarantee or delivery of the ordered items, as applicable.

Firms registered under MSME will be exempted from submitting EMD. In case of firms registered under NSIC, exemption will be given to the permissible extent, as indicated in their Certificate. All vendors claiming exemption must submit copies of their valid **MSME/NSIC registration Certificate** (along with the Technical Bid in case of two bid system). Offers received without Earnest Money or valid Certificate shall be summarily rejected.

15. **Performance Bank Guarantee (PBG):** The successful bidder shall furnish an unconditional PBG (asper format at Annexure II) for 5% of the Purchase Order value from a Nationalized/Scheduled Bank of India, before release of the payment. Else 5% of the billed amount will be deducted as security deposit. Where the PBG is obtained by a foreign bank, it shall be endorsed by a Nationalized/Scheduled Indian bank and shall be governed by Indian Laws and be subject to the jurisdiction of courts at Shillong. The PBG shall guarantee that,
 - The Vendor guarantees satisfactory operation of the Equipment & components against poor workmanship, bad quality of materials used, faulty designs and poor performance.
 - The Vendor shall, at his own cost, rectify the defects/replace the items supplied, for defects identified during the period of guarantee/warranty.

The PBG shall remain valid for period of (60) sixty days beyond the date of completion of all contractual obligations of the supplier including warranty obligations.

16. Delivery:

- a. Time Limit: **Maximum within 60 (sixty) days from the date of issue of Purchase Order (P.O).**
- b. Safe Delivery: **All aspects of safe delivery shall be the exclusive responsibility of the vendor.** At the destination site, the package will be opened only in the presence of the NIT user/representative and vendor’s representative. The intact condition of the package and the seal/indicators for not being tampered with shall form the basis for certifying the receipt in good condition.
- c. Insurance: The supplier is to establish ‘All Risk Transit Insurance’ coverage till door delivery at **NIT MEGHALAYA, PERMANENT CAMPUS, SAITSOHPEN, SOHRA-793108, MEGHALAYA.**
- d. Part Delivery: As far as possible no part delivery shall be entertained. However, in extreme cases, acceptance of part delivery shall be a prerogative of the Institute.

17. **Penalty for delay in delivery:** The date of delivery should be strictly adhered to. In the event of delayed

delivery, installation & commissioning, the vendor shall be liable for a penalty deduction at a percentage of the value of the undelivered equipment subject to a maximum of 10% (ten percent) as detailed below:

- a) @1% up to one week.
- b) @2.5% up to two weeks.
- c) @5% up to three weeks.
- d) @10% for four weeks and above

For this clause, part of the week is considered a full week. In case of delayed delivery, the Director, NIT Meghalaya reserves the right not to accept the subject consignment.

18. **Genuine Pricing:** The vendor is to ensure that the quoted price for the item is not more than the price quoted to any other customer in India, particularly to IITs/NITs/CFTI's. A copy of the latest price list for the quoted item, applicable in India, must be enclosed with the offer.
19. **Conditional tenders not acceptable:** All the terms and conditions mentioned herein must be strictly adhered to by all the vendors. Conditional tenders shall not be accepted on any ground and shall be rejected straightway. Conditions mentioned in the tender bids submitted by vendors will not be binding on NIT Meghalaya.
20. **Late and delayed tender:** Late and delayed tender will not be considered.
21. **Installation:** The bidder shall be solely responsible for the installation and commissioning of the items ensuring proper workmanship at site.
22. **Payment:**
 - a) 100% Payment within 45 days from the date of successful delivery, installation, and commissioning/ acceptance of goods at NIT Meghalaya, generally through PFMS.
 - i. OR
 - b) 85% Payment against delivery and 15% payment after successful installation and/ or commissioning of the ordered items at the site.
 - c) Part payment will not be made under any circumstances.
23. Payment will be made through PFMS. Bidders are required to furnish complete and correct bank details on their letterhead along with the technical bid. A scanned copy of a cancelled cheque may also be attached for verification of the IFSC code.
24. **Enquiry during evaluation not allowed:** After opening the Technical Bid, no enquiry from the bidder(s) shall be entertained during the evaluation of the tender till the final decision is conveyed to the successful bidder(s). However, the Purchase Committee or its authorized representative may make enquiries/seek clarification from the bidders. In such a case, the bidder must extend full cooperation. The bidders may also be asked to arrange a demonstration of the offered items, in a short period of notice.
25. At any time before the date of submission of the bid, NIT Meghalaya may, for any reason, either of its own or in response to a clarification from a prospective bidder, modify the bidding documents by an amendment/corrigendum. **Any such amendment/corrigendum will be duly notified through the CPP Portal and Institute website only.** Prospective bidders are advised to check the Institute's website every now and then for any amendment/corrigendum. To provide reasonable time to take the amendment into account in preparing the bid, NIT Meghalaya shall extend the date and time for the submission of bids.
26. The acceptance of the quotation will rest solely with the Director, NIT Meghalaya, who in the interest of the Institute is not bound to accept the lowest quotation and reserves the right himself to reject or partially accept any or all the quotations received without assigning any reasons.
27. **Force Majeure:**

If the performance of the obligation of either party is rendered commercially impossible by any of the

events hereafter mentioned that party shall be under no obligation to perform the agreement under order after giving notice of 15 days from the date of such an event in writing to the other party, and the events referred to are as follows:

- (a) Any law, statute or ordinance, order action or regulation of the Government of India,
- (b) Any kind of natural disaster, and
- (c) Strikes, acts of the public enemy, war, insurrections, riots, lockouts, sabotage.

28. **Termination for default:** Default is said to have occurred

- (a) If the items or any of its components is found to have poor workmanship, faulty designs, poor performance and bad quality of materials used.
- (b) If the supplier fails to deliver any or all the services within the period (s) specified in the purchase order or any extension thereof granted by NIT Meghalaya.
- (c) If the supplier fails to perform any other obligation(s) under the contract.

Under the above circumstances, NIT Meghalaya may terminate the contract/purchase order in whole or in part and forfeit the EMD/PBG as applicable. In addition to the above, NIT Meghalaya may at its discretion also take the following actions: NIT Meghalaya may procure, upon such terms and in such manner, as it deems appropriate, goods like the undelivered items/products and the defaulting supplier shall be liable to compensate NIT Meghalaya for any extra expenditure involved towards goods and services obtained.

29. **Applicable Law:**

- a. The contract shall be governed by the laws and procedures established by Govt. of India and subject to the exclusive jurisdiction of the Competent Court and Forum in Shillong/India only.
- b. Any dispute arising out of this purchase shall be referred to the Director, NIT Meghalaya, and if either of the parties hereto is dissatisfied with the decision, the dispute shall be referred to the decision of an Arbitrator, who should be acceptable to both the parties, to be appointed by the Director of the Institute. The decision of such Arbitrator shall be final and binding on both the parties.

30. **Compulsory Certificates, License etc. to be furnished:**

The bidder/OEM shall furnish and enclose the following important compulsory documents along with the technical bid of the tender, failing to do so may result in the rejection of the quotations received without assigning any reasons (as also mentioned in Page No. 1):

- i. **OEM's Factory License, Trademark certificate, OEM's India Design Mark Certificate and GRIHA certificate to be enclosed.**
- ii. **Dealership Certificate:** The bidder should be either an OEM (*Original Equipment Manufacturer*) or an authorized dealer/stockiest of the foreign/Indian OEM. Dealers or Agents quoting on behalf of the OEM must enclose a valid dealership certificate.
- iii. **BIFMA:** The bidder/OEM should be a member of BIFMA (*Business and Institutional Furniture Manufacturers Association*) and should provide a BIFMA level 6.1 certification for the product quoted.
- iv. **ISO Certificate:** The bidder/OEM should enclose the following ISO certificate:
ISO 9000/ ISO 14000/ ISO 45000/ISO 50000.
- v. **Green Guard Certificate** and the bidder/OEM should be a member of IGBC (*Indian Green Building Council*). **Green Factory Gold Certificate** should also be enclosed. The necessary documentation should be enclosed.
- vi. **AIOTA Certificate:** The bidder/OEM shall provide an AIOTA Certificate (*All India*

Occupational Therapists' Association) for at least some of its products.

- vii. Timely Servicing / Rectification of defects during warranty period: Manufacturers must agree to undertake a warranty for Three years for all the items supplied. After having been notified of the defects / service requirement during warranty period, Seller must complete the required Service/ Rectification within 15 days' time limit. If the Seller fails to complete service / rectification with defined time limit, a penalty of 0.2% of the Unit Price of the product shall be charged as penalty for each week of delay from the Seller. Seller can deposit the penalty with the Buyer directly else the Buyer shall have a right to recover all such penalty amount from the Performance Security (PBG). Cumulative Penalty cannot exceed more than 8% of the total contract value after which the Buyer shall have the right to get the Service/rectification done from alternate sources at the risk and cost of the Seller be sides forfeiture of PBG. The PBGs shall be valid throughout the warranty period plus two months after the supply of the furniture. Seller shall be liable to reimburse the cost of such service/ rectification to the Buyer.
- viii. **Black-listed or Debarment:** The bidder/OEM should submit an affidavit/notarized on non-judicial stamp paper that the bidder/OEM has never been black-listed or debarred for any of the products by any Government/semi-government/PSU/Bank/Universities/Educational Institute/Autonomous Institute for any reason.
- ix. **OEM's Required Machinery:** Documentary evidence of the machines available in their plant premises should be provided at the time of tender submission. Also, bidder/tenderer must furnish the Sample of the major items in the tender available at their premises, such as,
 - a) Beam saw for panel cutting
 - b) Through feed edge bander with PUR glue pot and pre-milling option
 - c) CNC machining center with horizontal, vertical drilling and grooving options
 - d) Curvilinear edge bander for edge banding curved edges
 - e) Calibrating sanding machine
 - f) Hot press for pressing laminate to raw board of minimum size 4 ft. x 8 ft.
 - g) Solid wood thickener
 - h) Wood turning lathe
 - i) Spray booth
 - j) Bent ply press with moulds
 - k) Upholstery setup
 - l) Pneumatic milling Machine
 - m) Compressor Machining Center
 - n) Precision Panel Bending Machine
 - o) Laser cutting machine
 - p) TIG/MIG welding machine, etc.

Additionally, if required, the committee may visit and check the manufacturing unit as well as the sample products to issue a technical competence or sample product certificate which in turn may need to be submitted in the tender.

- x. All documents should be valid at the time of tender submission and no "**APPLIED FOR**" document will be acceptable at all and the tender bid will be rejected without any further correspondence.

31. **Furniture Mock-up:** The bidder/OEM should carry-out a furniture mock-up on all/some of the items mentioned at the consignee's location after qualifying the techno commercial bid evaluation within 20 days from the award of the work at their own cost. NIT Meghalaya may ask for some minor technical/design modifications (if required) based on the samples presented during the mock-up. The final

products supplied at the consignee`s location should strictly adhere to the detailed technical specification as presented during the mock-up (including minor technical/design modifications, if any), if not, NIT Meghalaya has the full right to reject in whole or in part of the supplied items. Any cost involved thereof should be borne by the concerned bidder/tenderer.

32. **Testing of the supplied items:** The bidder/tenderer may need to perform necessary testing of the products at the discretion of NIT Meghalaya at the mock-up stage as well as at the time of final products delivery at the consignee`s location at their own cost. The bidder/tenderer should make all necessary arrangements for proper testing of the items at the consignee`s location.

Sd/-
Registrar

Encl.: ANNEXURE-I, ANNEXURE-II, ANNEXURE-III, ANNEXURE-IV, ANNEXURE-V.

ANNEXURE-I
A. DETAILED TECHNICAL SPECIFICATIONS

| Location | Item No | Name of the Item | Total Quantity (numbers) | Details Technical Specifications and Descriptions |
|--------------|---------|--|--------------------------|--|
| Lecture Hall | 01 | 2/3-seater Lecture hall integrated dual desk-bench | 1800 capacity |  <p align="center"><u>2/3-seater lecture hall integrated dual desk-bench (Sample Picture)</u> <u>(refer Annexure-IB for layout)</u></p> <p align="center"><u>Technical Specifications</u> (Also Refer Annexure-IC and refer picture above).</p> <p>Supply, Fitting & Fixing of Integrated Dual Desk:</p> <p>a. Desk-top: - Desktop post-forming is a manufacturing process used to create seamless, curved edges on laminated surfaces to enhance both the aesthetic appeal and the durability of the surface. The core material, made of MDF (medium-density fibre board), is cut to the desired shape and size of either Module A - 600WX568DX750H, or Module B- 600WX983DX750H, or Module C -600WX400DX750H</p> <p>The above Modules will be selected based on actual site conditions.</p> <p>b. Shelf: - Made up of 18mm thick Post laminated MDF Board. A "corner radius shelf" with rounded corners. This design element should be added for both aesthetic and practical reasons. Rounded corners can make a shelf safer by reducing the risk of injury from bumping into sharp edges, and they can also give the more modern, streamlined look. This process should enhance both the aesthetic appeal and the durability of the surface. Desk Surface should be made of Durable materials like high-pressure laminate 18mm THK Post formed laminated MDF Board. The term 'post forming' should be used to describe the bending process applied to specially developed grades of laminate which, whilst possessing all the well-known properties of standard grade high pressure laminates. After that lamination of top process should involve gluing a decorative layer, often a high-quality Merino sheet of 0.8mm thick on both sides.</p> |

| Location | Item No | Name of the Item | Total Quantity (numbers) | Details Technical Specifications and Descriptions |
|----------|---------|------------------|--------------------------|---|
| | | | | <p>c. Modesty & Seat: Made up of 12mm thick Moulded ply made by gluing together thin layers of wood ply, with each layer's grain oriented perpendicular to the adjacent layers. This cross-grain construction should give plywood its strength and stability. The cross-grain construction of plywood should give high strength and resistance to warping and splitting. Moulded plywood should be used due to its versatility and innovative material that combines the natural beauty and strength of wood with the flexibility to create complex shapes, the seats are further upholstering with Leatherette (refer sample picture) and have a cushion of 25 mm thickness.</p> <p>d. Metal Under structure: Vertical legs should be made up of laser cutting plate which has the advantage over of being more precise. 8 mm thick steel plates should be provided for substantial strength and support and should use laser inhouse facility for high precision to enable intricate designs and tight tolerances. The cutting process should produce clean, burr-free edges, reducing the need for additional finishing.</p> <p>Base plate also plates up of laser cutting plate 6mm thick MS Plate and the frame finished with powder coat up to 60 -80 MICRON with Nano powder. Top support bracket should be made up of 2mm thick. Top cross member should be made up of 50x25X1.2mm thick rectangular pipe with grade A and should have a fair strength and weldability.</p> <p>Side-bag Hooks: Attached to the sides of the desk, making them visible and easy to reach.</p> <p>Bottom cross member should be made up of ISMC 75 SECTION finished with powder coat up to 60 -80 MICRON with Nano powder.</p> <p>Seat assembly should be made up of combination of 4mm thick MS Plate and the frame finished with powder coat up to 60 -80 MICRON with Nano powder. Mounted on 3.0mm thick MS spring. And covered with cover made up of PP.</p> <p>An auto tip-off mechanism for a desk seat should be a system designed to enhance ergonomics, safety, and convenience for users. These mechanisms should ensure proper seating posture. And should be a most valuable addition to modern furniture.</p> <p>An aluminium extrusion top cover which is a versatile and durable component used in various applications to provide protection, aesthetic appeal, and structural support. These covers should be produced through the extrusion process, where aluminium should be forced through a die to create long, uniform shapes with specific cross-sectional profiles. It should add a premium look to desk while</p> |

| Location | Item No | Name of the Item | Total Quantity (numbers) | Details Technical Specifications and Descriptions |
|----------|---------|------------------|--------------------------|--|
| | | | | <p>providing structural integrity.</p> <p>e. Bottom Shoe: - Should be made up of Polypropylene which is more heat resistance material. Should be non-toxic composition, good heat and chemical resistance, low potential for leaching harmful substances, and compliance with regulatory standards to contribute to its overall safety profile.</p> <p>The thermal properties should be such that it can withstand temperatures up to 100-120°C (212-248°F) without deforming. Also, the material should have Low Environmental Impact meaning to have fewer emissions during manufacturing compared to some other plastics.</p> <p>Should be Integrated with electrical components into the desks which can significantly enhance the functionality and convenience for students and faculties, providing easy access to power and data connectivity.</p> |

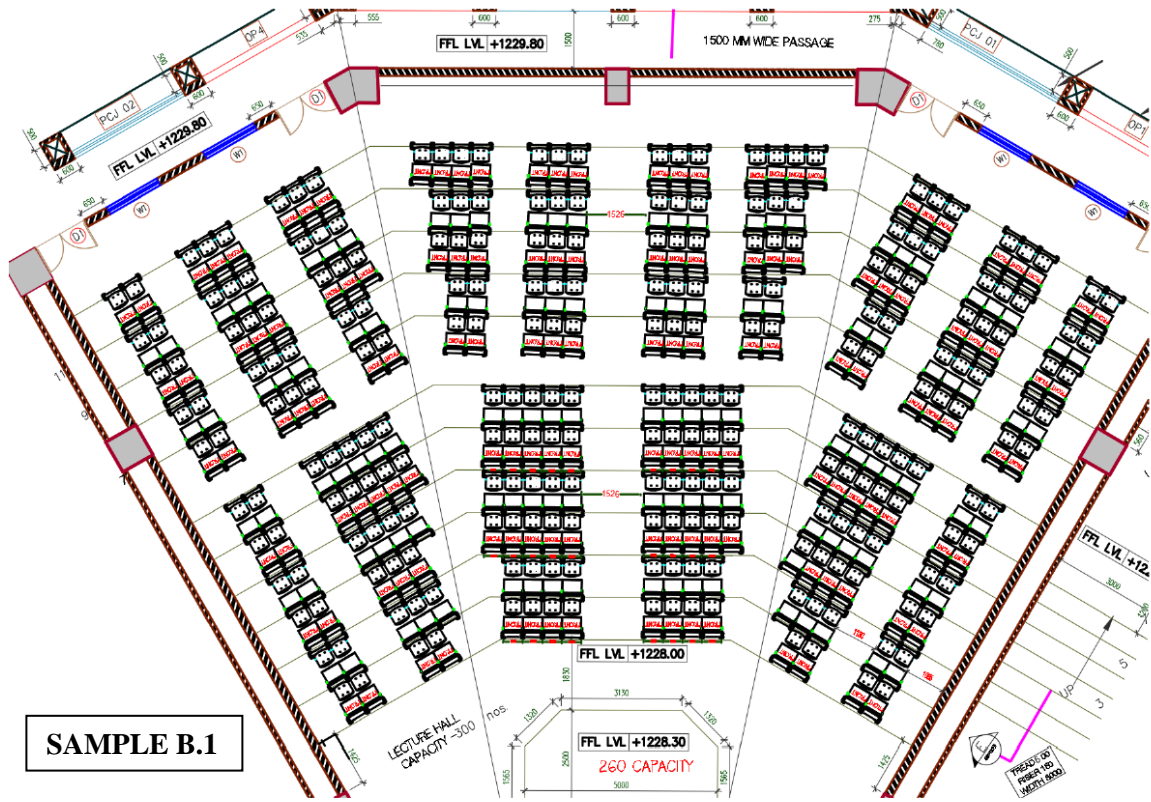

SAMPLE B.1

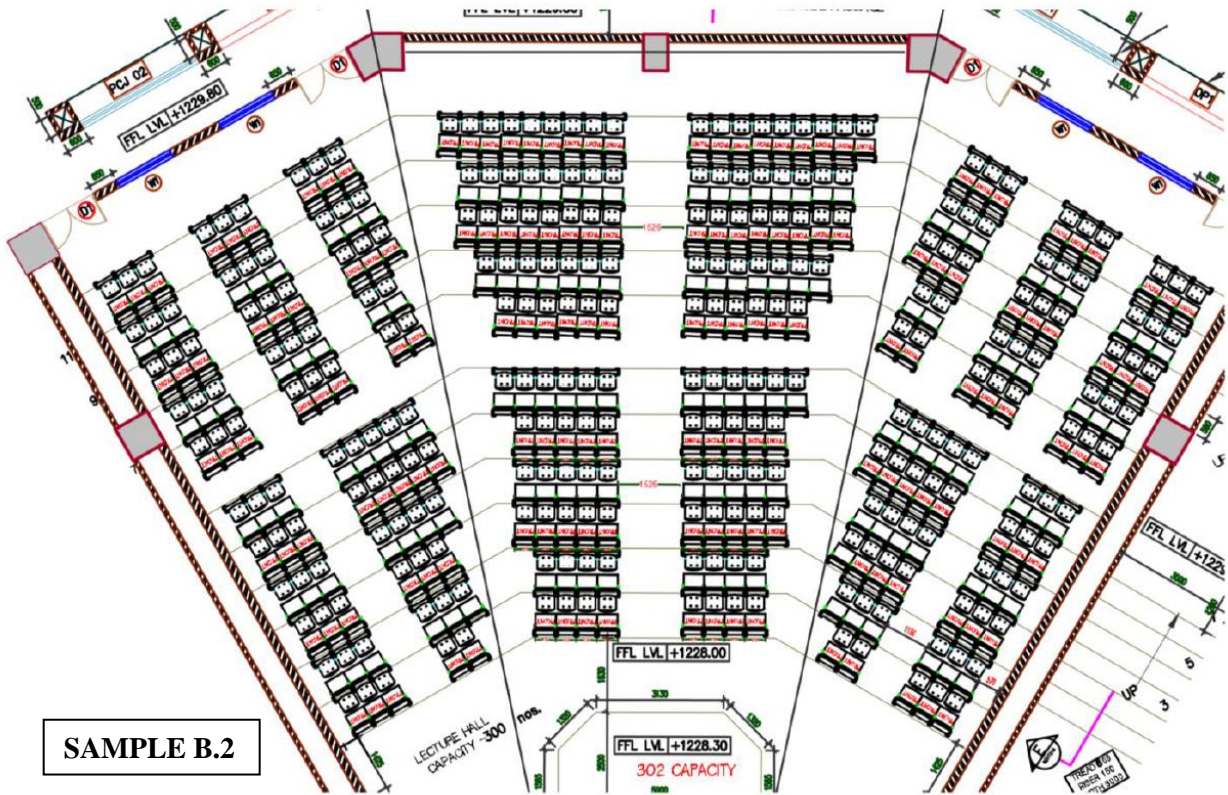

SAMPLE B.2

Lecture Hall of bigger room size (either Sample B.1 or B.2 may be adopted) – 2 nos

The two-sample layout provided is tentative and may subject to change as per NIT Meghalaya requirements.

ANNEXURE-I

C. TENTATIVE INTEGRATED DUAL DESK BENCH LAYOUT (All dimensions in mm)

ALL FRONT-ROW SEATING SCHEMATIC DIAGRAM

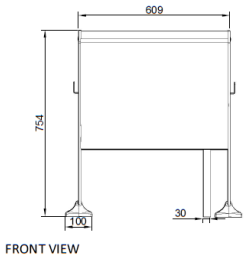

FRONT VIEW

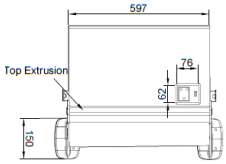

TOP VIEW

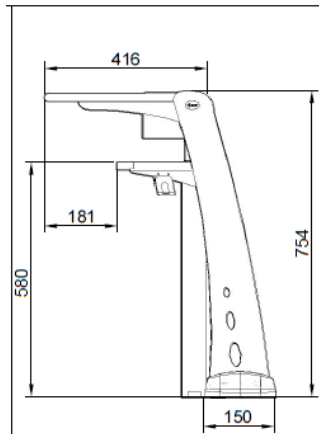

SIDE VIEW

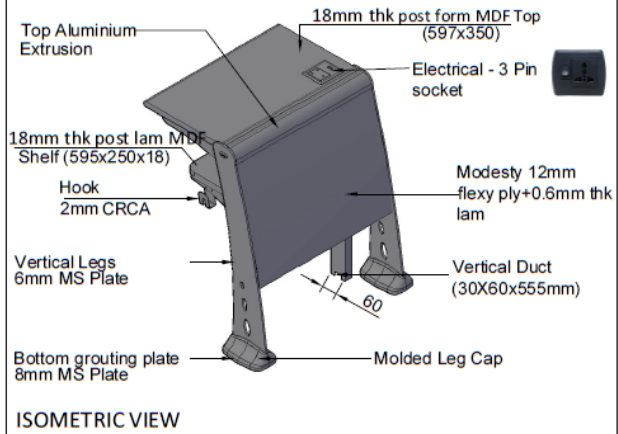

ISOMETRIC VIEW

ALL MID-ROW SEATING SCHEMATIC DIAGRAM

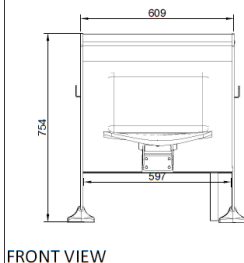

FRONT VIEW

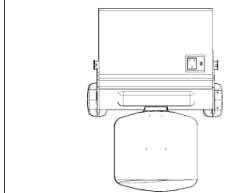

TOP VIEW

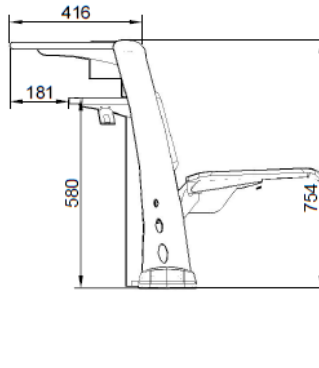

SIDE VIEW

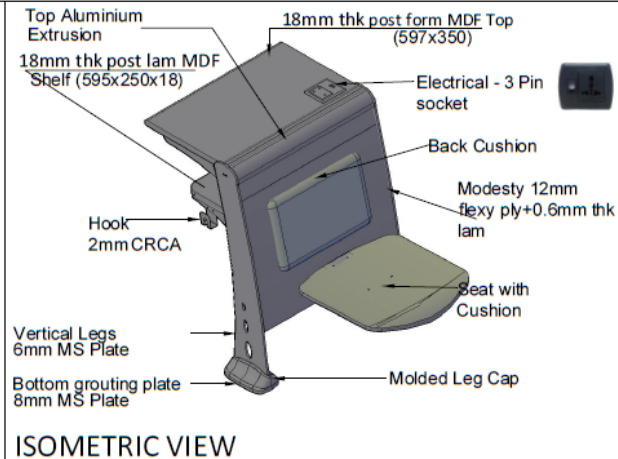

ISOMETRIC VIEW

ALL BACK-ROW SEATING SCHEMATIC DIAGRAM

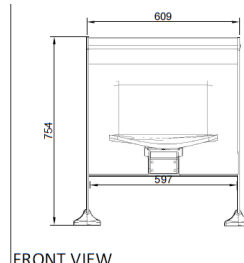

FRONT VIEW

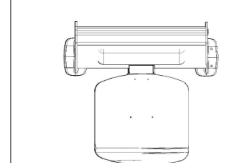

TOP VIEW

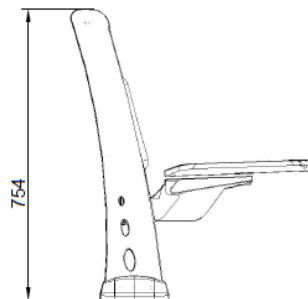

SIDE VIEW

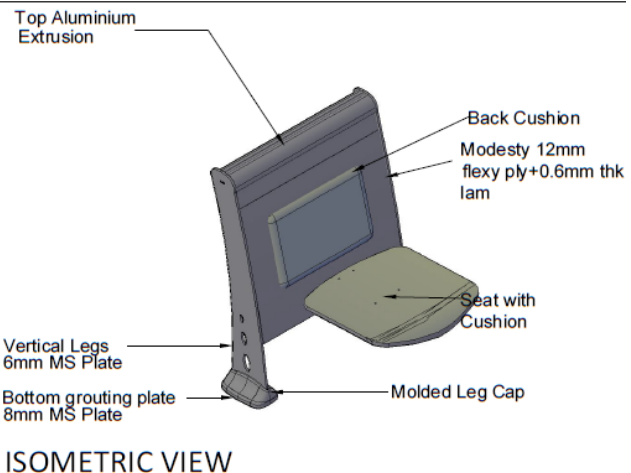

ISOMETRIC VIEW

ANNEXURE-II

A. COMPLIANCE CERTIFICATE FOR NIQ TERMS AND CONDITIONS

(To be enclosed in the technical bid)

Certify that we have carefully examined the NIQ terms and fully understood its implications and do hereby agree to comply with all the terms, and hereby submit this compliance certificate.

| Sl. No. | NIQ Terms and Conditions | Yes/No |
|----------------|--|---------------|
| 01 | <u>Bidder's Eligibility Criteria</u> complied. | |
| | • The bidder should be a supplier/dealer/OEM. | |
| | • It is essential that the bidder should be able to provide support during the warranty as per requirement of NIT Meghalaya. | |
| | • The bidder must submit an affidavit confirming that the bidder has never been blacklisted in any Government Institutes/Organization or PSU. | |
| | • The Bidder must possess a valid GST Registration Certificate, PAN Number. (Copy of the certificates to be submitted). | |
| | • The Bidder shall not be under a Declaration of Ineligibility for corrupt or Fraudulent Practices with any Government departments/ agencies/ ministries or PSU's and should not be blacklisted as on submission of the NITM. A declaration by authorized signatory of the Bidder must be enclosed | |
| | • The bidder should have executed the similar order of the quoted item in any reputed Govt. Institute such as NIT`s/ IIT`s or CFTI`s. | |
| 02 | Rate quoted as per instruction | |
| 03 | Validity of quoted rate for 120 days agreed | |
| 04 | Payment term agreed | |
| 05 | Delivery terms agreed | |
| 06 | Warranty period agreed | |
| 07 | Literature: Printed Literature provided | |
| 08 | Dealership / distributorship certificate (in case of dealers/agents) provided | |
| 09 | Details of supply to other Institutes of National Importance provided | |
| 10 | After Sales Service: address of nearest after Sales Service center in the region provided | |
| 11 | Manufacturer certificate provided | |
| 12 | Applicable law terms agreed | |
| 13 | Compulsory Certificates/License etc. to be furnished: Enclosures as per Sl no 30 | |

Signature with Seal:.....

Vendor: M/s.....

ANNEXURE-II

B. COMPLIANCE CERTIFICATE FOR SPECIFICATIONS

(One for each item, must be enclosed in the technical bid)

| Item Sl. No. | | Item Name: | |
|------------------------------------|---------------|-----------------------------|--------------------|
| Quoted Product: | Make: | Model No: | |
| Specifications as per Annexure-III | | Quoted Item Specifications* | Complied/Deviation |
| Parameter | Specification | | |
| | | | |
| | | | |
| | | | |
| | | | |
| | | | |
| | | | |
| | | | |
| | | | |
| | | | |
| | | | |

Signature with Seal:.....

Vendor: M/S.....

*** Vendor must quote the parameter specification of the quoted product in this column and not just copy the specification from the tender call document. Failure to do so will lead to rejection of the tender.**

ANNEXURE-III
BIDDERS DETAIL

| Sl. No. | Name of the company/Firm | To be filled by vendor (Documentary Proof must be attached as applicable) |
|---------|--|--|
| 01 | Registered office Name & Address Details of contact person Name designation Telephone number e-mail | |
| 02 | Name & Address of nearest service provider City Contact person/s Name designation Telephone number e-mail Details with contact no. of staff who will be involved in this project. | |
| 03 | Is the company/firm a registered company/firm? If yes, mention year and place of the establishment of the company and submit documentary proof. | |
| 04 | Is the company/firm registered for GST? If yes, submit valid registration certificate. | |
| 05 | List the major clients with whom your organization has been associated and submit documentary proof/PO. | |

Note: Document/s if attached to the NIQ compliance Certificate the same may be referred to in the remark column above

Sign. :.....
Vendor : M/s.....

ANNEXURE-IV

PERFORMANCE BANK GUARANTEE

To:
The Registrar,
National Institute of Technology Meghalaya
Bijni Complex, Laitumkhrah, Shillong –
793003, Meghalaya.

WHEREAS(Name of Supplier) herein after called "the Supplier" has undertaken, in pursuance of Contract No:, dated: 20..... to supply.....
.....(Description of Goods and Services) herein after called "the order".

AND WHEREAS it has been stipulated by you in the said order that the Supplier shall furnish you with a Bank Guarantee by a recognized bank for the sum specified therein as security for compliance with the Supplier's performance obligations in accordance with the order.

ANDWHEREAS we have agreed to give the Supplier a Guarantee:
THEREFORE WE hereby affirm that we are Guarantors and responsible to you, on behalf of the Supplier, up to a total of (Amount of the Guarantee in Words and Figures) and we undertake to pay you, upon your first written demand declaring the Supplier to be in default under the order and without cavil or argument, any sum or sums within the limit of.....
(Amount of Guarantee) as aforesaid, without your needing to prove or to show grounds or reasons for your demand or the sum specified therein.

This guarantee is valid until the.....day of.....20.....

Signature and Seal of Guarantors

.....
.....
.....

Date.....20....

Address:.....

.....
.....

All correspondence with reference to this guarantee shall be made at the following

Address: The Registrar,
National Institute of Technology Meghalaya
Bijni Complex, Laitumkhrah, Shillong-793003, Meghalaya

ANNEXURE-V

TENDER ACCEPTANCE LETTER
(To be given on Company Letter Head)

Ref. No.

Date:

To,

The Registrar
National Institute of Technology Meghalaya
Bijni Complex, Laitumkhrah
Shillong 793003, Meghalaya

Sub: Acceptance of Terms & Conditions of Tender.

Tender Reference No.: NITMGH/..... dated2021

Name of Tender:-

Sir,

1. I / We have downloaded / obtained the tender document(s) for the above-mentioned Tender from the website of NIT Meghalaya, Shillong as per your advertisement, given in the CPP Portal and the above mentioned website.
2. I / We hereby certify that I / we have read the entire terms and conditions of the tender documents from Page No.....to (including all annexure(s), schedule(s),etc.),which form part of the contract agreement and I / we shall abide hereby by the terms / conditions / clauses contained therein.
3. The corrigendum(s), if any, issued from time to time by NIT Meghalaya, Shillong, have also been taken into consideration, while submitting this acceptance letter.
4. I / We hereby unconditionally accept the tender conditions of above-mentioned tender document(s) /corrigendum(s)in its totality/ entirety.
5. I/WedoherebydeclarethatourFirmhasnotbeenblacklisted/debarredbyanyGovt.Department/Publicsectorundertaking.
6. I / We certify that all information furnished by our Firm is true & correct and in the event that the information is found to be incorrect/untrue or found violated, then NIT Meghalaya, Shillong shall without giving any notice or reason therefore or summarily reject the bid or terminate the contract, without prejudice to any other rights or remedy including the forfeiture of the full said earnest money deposit absolutely.

Yours Faithfully,

(Signature of the Bidder, with Official Seal)
